

Mini DC - Isolators for Photovoltaic acc. to IEC 60364-7-712

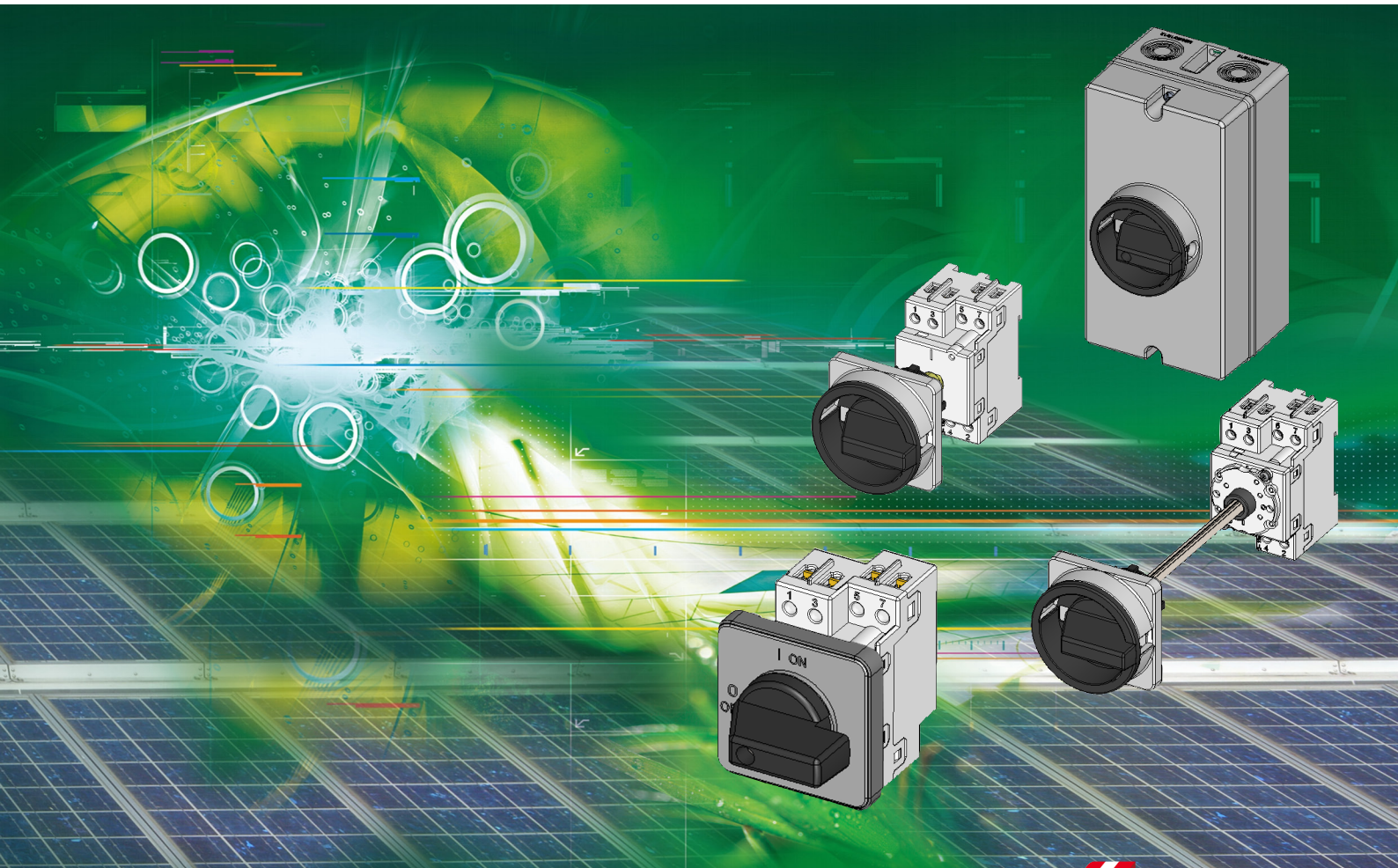

Quality made in  AUSTRIA

D912E176

Ratings			
Type	I _{in} open A	Rated Current	
		DC21B(DC-PV1) 4 poles in series A	at U _e V
LSM16	16	16	1000
LSM25	25	25	1000

Mini DC-Switch Disconnectors

Design	Panel mounting Four hole mounting IP66 ¹⁾	Panel mounting Two hole mounting IP66 ¹⁾	Single hole with door coupling Ø22,5mm, IP66 ¹⁾	Single hole with door coupling Ø16mm, IP66 ¹⁾

LSM16	16	16	1000	..E, EH4..	..E2, E2H1..	..Z(O), ZH1..	..Z16, Z16H4..
LSM25	25	25	1000	..E, EH4..	..E2, E2H1..	..Z(O), ZH1..	..Z16, Z16H4..

Mini Switch Disconnectors for Photovoltaic

Mini Switch Disconnectors „LSM“ are switch gears for interrupting the DC/AC-Inverter from solar-panels. Photovoltaic-Installations have to be equipped with DC-Isolators acc. to IEC 60364-7-712.

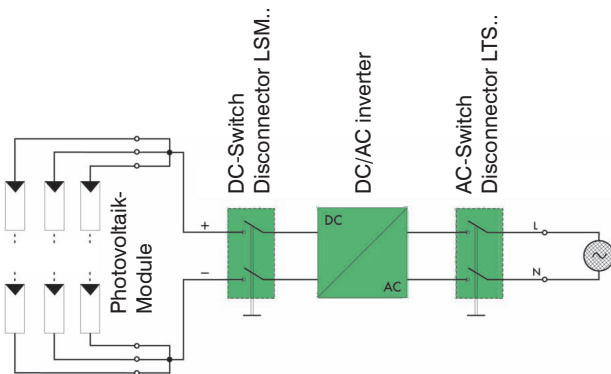

Mini Switch Disconnectors LSM ensure a reliable switching up to 25A at 1500V in the category DC21B (DC-PV1).

The construction of the contacts and the material selection guarantee that no oxidations develop (because of small switching frequency) and further it is prevented that inadmissible heating-up is effected.

Mini Switch Disconnectors LSM are equipped with 2 or 4 switchable, singular contacts. By serial or parallel wiring of the contacts the contact rating will be increased.

The switching speed by the manually driven handle does not have an effect on the switching attitude of the contacts.

Switching programs

Type	2-pole	2+2-pole 2 poles in series + 2 poles parallel	4-pole	4-pole with jumpers Input and Output bottom	4-pole with jumpers Input and Output top
LSM16	.. A2	.. A2+2	.. A4(2 x A2)	.. A4O	.. A4U
LSM25	.. A2	.. A2+2	.. A4(2 x A2)	.. A4O	.. A4U

Contact
Wiring diagram

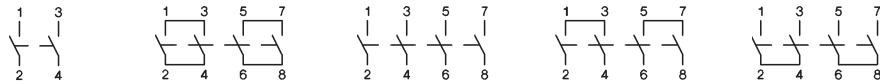

Switching example

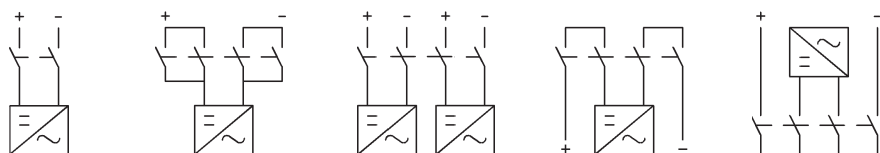

Ordering

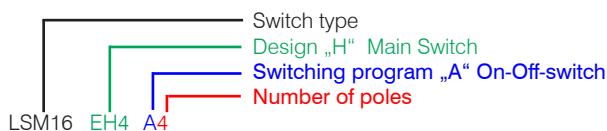

1) Protection in front and built in

Mini DC-Switch Disconnectors

Base mounting with door coupling, single hole, Ø22,5mm, IP66¹⁾

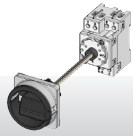

..VZV, VZVH4..
..VZV, VZVH4..

Modular Switch IP40¹⁾

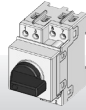

..SMA, SMAH1..
..SMA, SMAH1..

Plastic enclosed PFL..IP67¹⁾

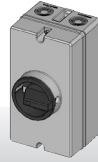

..PFLH4..
..PFLH4..

Technical data for DC, according to IEC 60947-3, VDE0660

Typ	Diagram	LSM16.. LSM25..	DC21A/B (DC-PV1)							DC22B				
			500V	600V	700V	800V	900V	1000V	1200V	1500V	500V	600V	800V	1000V
2 Pole in Serie		LSM16.. LSM25..	16A 25A	16A 25A	16A 25A	16A 19A	16A 17A	10A 11,5A	7A 8,5A	3A 5A	7A 8A	5,5A 6A	2A 2,5A	1A 1,5A
2 Pole in Serie + 2 parallel		LSM16.. LSM25..	29A 45A	29A 36A	22A 27A	17A 19A	16A 17A	10A 12A	7A 9A	3A 5A	-	-	-	-
4 Pole in Serie		LSM16.. LSM25..	16A 25A	16A 25A	16A 25A	16A 25A	16A 25A	16A 25A	16A 25A	16A 25A	16A 25A	16A 25A	11,5A 12A	8A 9A

Isolated jumper LSMV-.. for series and parallel switching of contacts (terminals 1-3, 5-7, 2-4, 6-8)

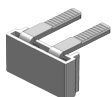

Type	Pack	Weight	
LSM16, LSM25	LSMV-B1	100	6,0 g/pc.

1) Protection in front and built in

Technical Data

Kind of current	Category	Typical applications	Test conditions for the number of on-load operating cycles (normal service)						Test conditions for making and breaking capacities (operation in fault case)						
			Make I/le	U/Ue	L/R	Break Ic/le	Ur/Ue	L/R	Make I/le	U/Ue	L/R	Break Ic/le	Ur/Ue	L/R	
Direct current	DC21A frequent operation	DC21B infrequent operation	Switching of resistive loads including moderate overloads	1	1	1ms	1	1	1ms	1,5	1,05	1ms	1,5	1,05	1ms
	DC22A frequent operation	DC22B infrequent operation	Switching of mixed resistive a.induct. loads incl. moderate overloads (shunt motors)	1	1	2ms	1	1	2ms	4	1,05	2,5ms	4	1,05	2,5ms
	DC-PV1		Switching of single PV string(s) without reverse- and overcurrents.	1	1	1ms	1	1	1ms	1,5	1,05	1ms	1,5	1,05	1ms
	DC-PV2		Switching of several PV strings with reverse- and overcurrents.	1	1	1ms	1	1	1ms	4	1,05	1ms	4	1,05	1ms

Data according to IEC 60947-3, VDE 0660, GB14048.3 (CCC China)

Main contacts		Type	LSM16	LSM25		
Rated thermal current I_{th}		A	16	25		
Rated insulation voltage U_i ¹⁾		V	1000	1000		
Rated insulation voltage U_i ²⁾		V	1500	1500		
Distance of contacts (per pole)		mm	8	8		
DC21A and DC21B	1 pole A1	300V	A	16	23	
		400V	A	12	14	
		500V	A	9	11	
		600V	A	6	8	
		700V	A	4,5	6	
		800V	A	3	4	
		900V	A	2,5	3	
		1000V	A	1,5	2	
		2 poles in series A2	500V	A	16	25
			600V	A	16	25
	700V		A	16	23	
			800V	A	16	20
			850V	A	18 ³⁾	22 ³⁾
			900V	A	13	16
	1000V	A	9	11		
	2 poles in series + 2 poles parallel A2 + 2	500V	A	29	45	
		600V	A	29	45	
		700V	A	16	23	
			800V	A	16	20
			900V	A	13	16
1000V			A	9	11	
1200V	A	6	8			
1500V	A	3	4			
4 poles in series A4	500V	A	16	25		
	600V	A	16	25		
	700V	A	16	25		
		800V	A	16	25	
		900V	A	16	25	
		1000V	A	16	25	
		1200V	A	16	25	
	1500V	A	16	20		
AC21B	A2, A4	U_g max. 440V	A	16	25	
	A2 + 2	U_g max. 440V	A	29	45	



1) Suitable at overvoltage category I to III, pollution degree 3 (standard-industry): $U_{imp} = 8kV$.

2) Suitable at overvoltage category I to III, pollution degree 2 (min. IP55): $U_{imp} = 8kV$.

3) DC21B only

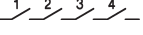

Technical Data

Data according to IEC 60947-3, VDE 0660

Main contacts		Type	LSM16	LSM25	
Rated operational current I_e DC-PV1	300V	A	16	23	
	400V	A	14	22	
1 pole A1 	500V	A	10	17	
	600V	A	7	12	
	700V	A	5	6	
	800V	A	3	4	
	900V	A	3	3	
	1000V	A	2	2	
	2 poles in series A2 	500V	A	16	25
600V		A	16	25	
700V		A	16	25	
800V		A	16	19	
900V		A	16	17	
1000V		A	10	11,5	
1100V		A	8	10	
1200V		A	7	8,5	
1300V		A	6	7	
1400V		A	5	6	
1500V		A	3	5	
2 poles in series + 2 poles parallel A2+2 		500V	A	29	45
		600V	A	29	36
	700V	A	22	27	
	800V	A	17	19	
	900V	A	16	17	
	1000V	A	10	11,5	
	1100V	A	8	10	
	1200V	A	7	8,5	
	1300V	A	6	7	
	1400V	A	5	6	
	1500V	A	3	5	
	4 poles in series A4 	500V	A	16	25
		600V	A	16	25
700V		A	16	25	
800V		A	16	25	
900V		A	16	25	
1000V		A	16	25	
1100V		A	16	25	
1200V		A	16	25	
1300V		A	16	25	
1400V		A	16	25	
1500V		A	16	25	

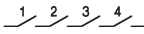

Technical Data

Data according to IEC 60947-3, VDE 0660



Main contacts		Type	LSM16	LSM25	
Rated operational current I_e DC-PV2	300V	A	16	23	
	400V	A	15	18	
1 pole A1 	500V	A	10	12	
	600V	A	5	6	
	700V	A	1,5	2	
	800V	A	1,5	2	
	900V	A	1	1,5	
	1000V	A	1	1,5	
	2 poles in series A2 	500V	A	16	25
600V		A	14	21	
700V		A	13	19	
800V		A	12	15	
900V		A	8	10	
1000V		A	4	5	
1100V		A	3	4	
1200V		A	2	3	
1300V		A	1,5	2	
1400V		A	1	2	
1500V		A	1	1,5	
2 poles in series + 2 poles parallel A2+2 		500V	A	25	39
		600V	A	20	32
	700V	A	13	19	
	800V	A	12	15	
	900V	A	8	10	
	1000V	A	4	5	
	1100V	A	3	4	
	1200V	A	2	3	
	1300V	A	1,5	2	
	1400V	A	1	2	
	1500V	A	1	1,5	
4 poles in series A4 	500V	A	16	25	
	600V	A	16	25	
	700V	A	16	25	
	800V	A	16	25	
	900V	A	16	25	
	1000V	A	16	25	
	1100V	A	16	25	
	1200V	A	13,5	21	
	1300V	A	12	19	
	1400V	A	10,5	16	
	1500V	A	9	14	

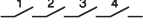

Technical Data

Data according to IEC 60947-3, VDE 0660

Main contacts		Type	LSM16	LSM25
Rated operational current I_e DC22B	1 pole	500V A	1	1,25
	A1 	600V A	0,5	0,75
		800V A	0,3	0,4
		1000V A	0,15	0,2
		1200V A	-	-
		1500V A	-	-
	2 poles in series A2 	500V A	7	8
		600V A	5,5	6
		800V A	2	2,5
		1000V A	1	1,5
		1200V A	-	-
	4 poles in series A4 	500V A	16	25
		600V A	16	25
		800V A	11,5	12
		1000V A	8	9
1200V A		-	-	
	1500V A	-	-	
Rated conditional short-circuit current		kA _{eff}	5	5
Max. fuse size		gL (gG)	40	63
Mechanical life		x10 ³	10	10
Rated short-time withstand current (1s)	l _{cw}	A2, A4	800	900
		A2+2	1300	1500
Short circuit making capacity	l _{cm}	A2, A4	800	900
		A2+2	1300	1500
Maximum cable cross sections (incl. jumper LSMV-B1)				
solid or stranded		mm ²	1,5 - 10	4 - 10
flexible		mm ²	1,5 - 6	4 - 10
flexible (+ multicore cable end)		mm ²	1,5 - 6	4 - 10
Size of terminal screw			M3,5 Pz1	M3,5 Pz1
Tightening torque		Nm	1,4	1,4
2 cables per clamp without jumper LSMV-B1				
solid or stranded		mm ²	10+(1,5-2,5) / 6+(1,5-6) / 4+(1,5-4)	
flexible		mm ²	(0,5-6) + (0,5-6)	
stranded		AWG	6+(20-14) / 8+(20-12) / 10+(20-10) 12+(20-12)	
solid		AWG	10+(16-10) / 12+(16-12) 14+(16-14)	
Maximum ambient temperature				
Operation	open	°C	-40 to +65	
	enclosed	°C	-40 to +45	
Storage		°C	-50 to +90	
Power loss per switch at I _e max.			A	A
A2	(A)/ W	(16)/	1	(25)/ 2,3
A4	(A)/ W	(16)/	2	(25)/ 4,6
A2+2	(A)/ W	(29)/	1,5	(45)/ 3,7
Contact resistance per pole		mΩ	1,75	1,75



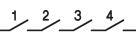

Technical Data

Data according to UL508  File E359344, Category no.: NMSJ, and UL508  File E332938, Category no.: NRNT2, NRNT8

Type			LSM16	LSM25	
Ampere-Rating "General use"  1 pole	DC				
	350V	A	4	5	
	500V	A	4	5	
	600V	A	4	5	
	700V	A	-	-	
	800V	A	-	-	
	900V	A	-	-	
	1000V	A	-	-	
	 2 poles in series A2	350V	A	16	25
		500V	A	16	25
600V		A	16	25	
700V		A	-	-	
800V		A	-	-	
900V		A	-	-	
1000V		A	-	-	
 2 poles in series + 2 poles parallel A2+2		350V	A	29	45
	400V	A			
	500V	A	29	38	
	600V	A	21	27	
	700V	A	-	-	
	800V	A	-	-	
	900V	A	-	-	
	1000V	A	-	-	
 4 poles in series A4	350V	A	16	25	
	500V	A	16	25	
	600V	A	16	25	
	700V	A	-	-	
	800V	A	-	-	
	900V	A	-	-	
	1000V	A	-	-	
Fuse size (RK5) Industrial Control Switch 5kA / 600V	A		40	60	
Maximum cable cross sections (incl. jumper LSMV-B1)					
solid or stranded	AWG		16 - 10	16 - 10	
flexible	AWG		20 - 6	20 - 6	
flexible (+ multicore cable end)	AWG		20 - 6	20 - 6	
Size of terminal screw			M3,5 Pz1	M3,5 Pz1	
Tightening torque	lb.inch		12,4	12,4	
Protection class of terminals ¹⁾			IP20	IP20	

1) Protection degree of the terminals with connected insulated conductor.

Approvals

Country	USA, UL508 	US, Canada UL508 	Europe 	China CCC 	CB- certificates	EAC 
Type						
LSM16	x	x	/	x	x	o
LSM25	x	x	/	x	x	o

o In standard version approved

/ No testing required CE

x pending

- not provided for testing till now

Technical Data

Maximum current according to ambient temperature and cable cross section

Switch open LSM16..., 2 contacts in series (A2)

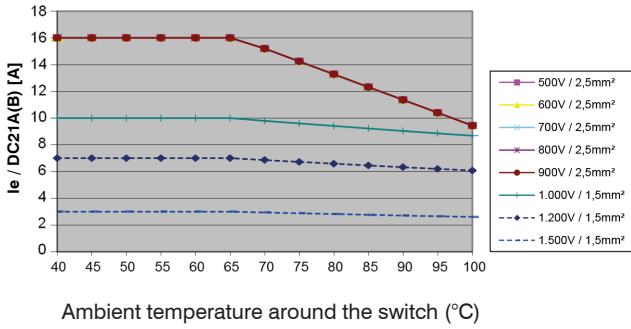

Switch open LSM16 ..., 2 contacts in series + 2 parallel (A2+2)

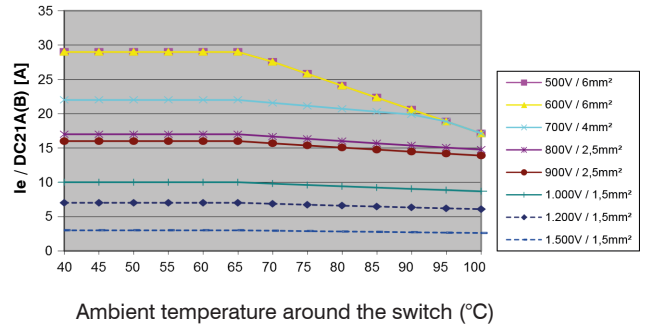

Switch open LSM16..., 4 contacts in series (A4x)

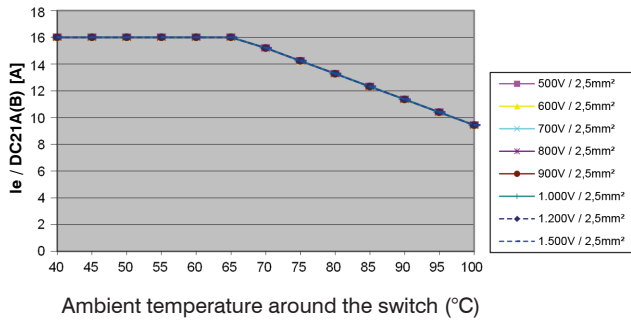

Switch enclosed LSM16 PFL..., 2 contacts in series (A2)

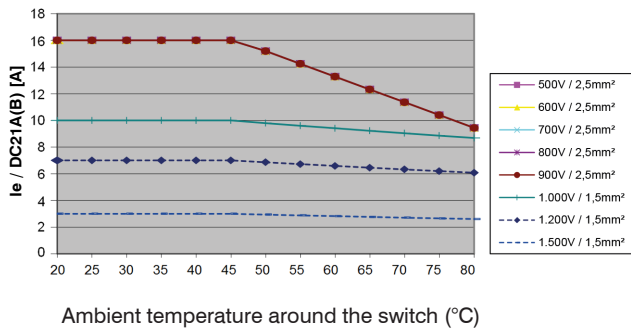

Switch enclosed LSM16 PFL..., 2 contacts in series + 2 parallel (A2+2)

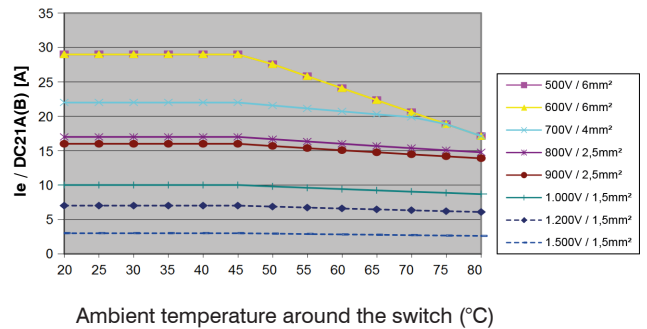

Switch enclosed LSM16 PFL..., 4 contacts in series (A4x)

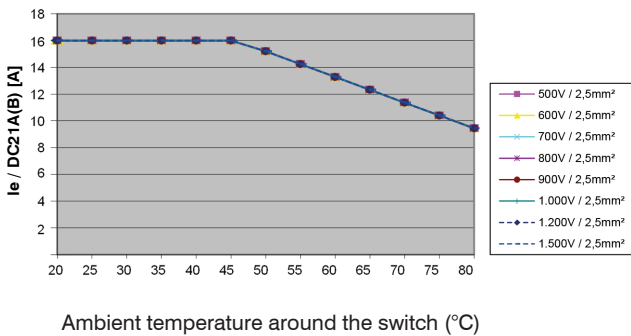

Technical Data

Maximum current according to ambient temperature and cable cross section

Switch open LSM25..., 2 contacts in series (A2)

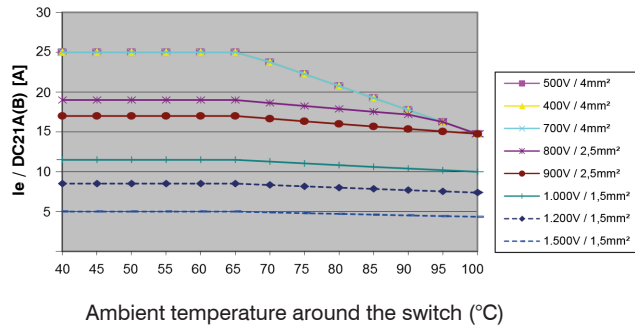

Switch open LSM25 ..., 2 contacts in series + 2 parallel (A2+2)

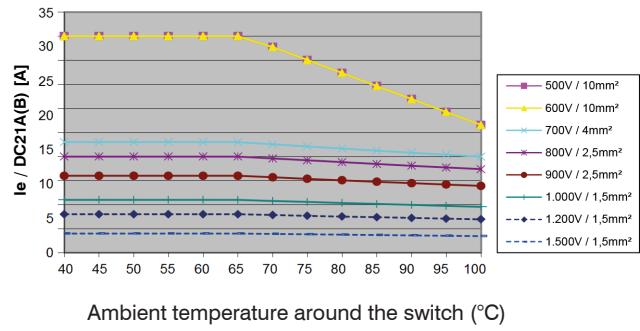

Switch open LSM25..., 4 contacts in series (A4x)

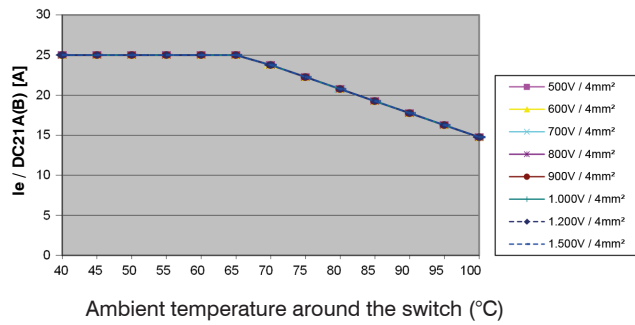

Switch enclosed LSM25 PFL..., 2 contacts in series (A2)

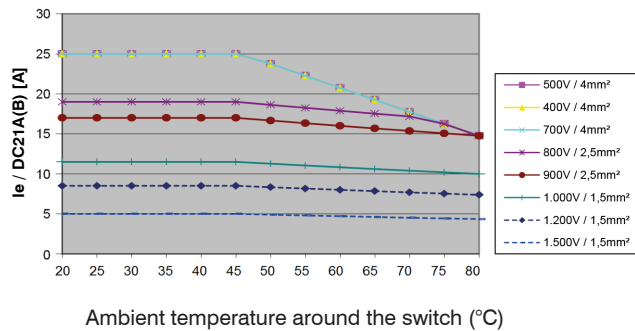

Switch enclosed LSM25 PFL..., 2 contacts in series + 2 parallel (A2+2)

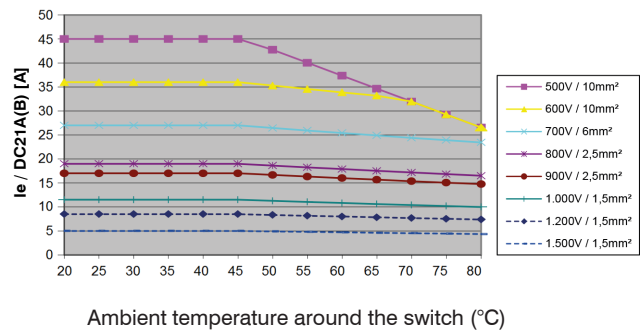

Switch enclosed LSM25 PFL..., 4 contacts in series (A4x)

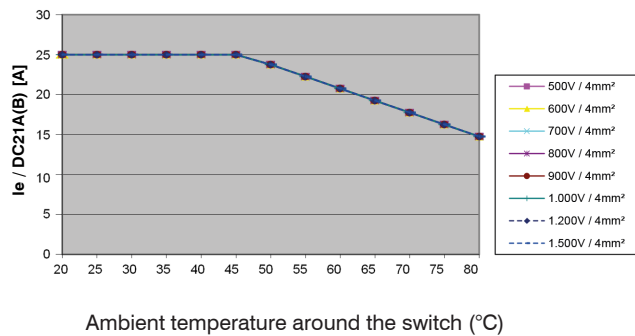

Dimensions:

**LSM16 E..., LSM25 E...,
..A2**

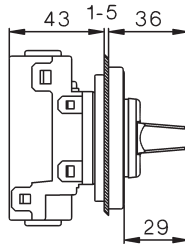
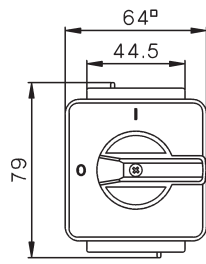

Mounting hole

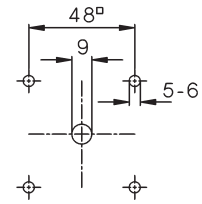

**LSM16 E..., LSM25 E...,
..A2+2, ..A4**

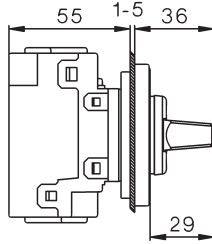
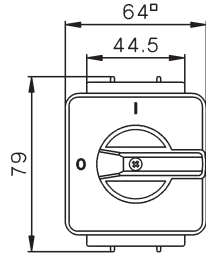

Mounting hole

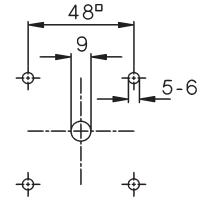

**LSM16 E2..., LSM25 E2...,
..A2**

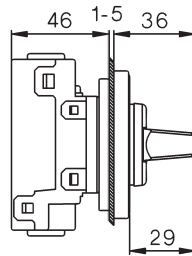
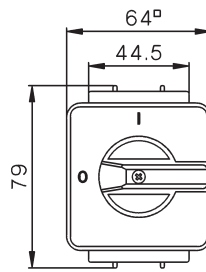

Mounting hole

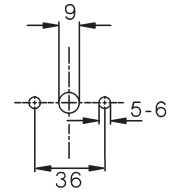

**LSM16 E2..., LSM25 E2...,
..A2+2, ..A4**

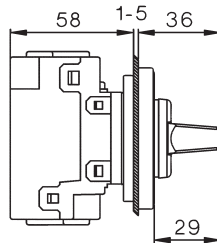
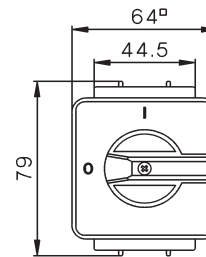

Mounting hole

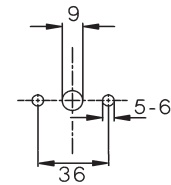

**LSM16 Z..., LSM25 Z...,
..A2**

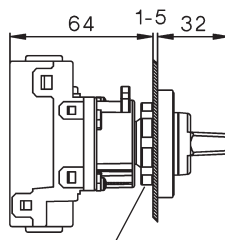
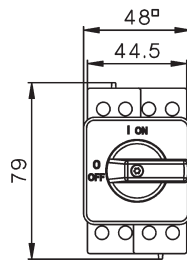

Mounting hole

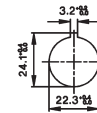

0,8 Nm

**LSM16 Z..., LSM25 Z...,
..A2+2, ..A4**

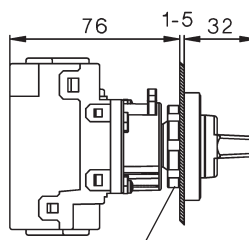
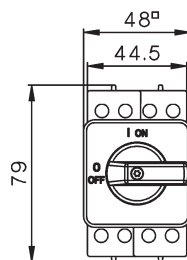

Mounting hole

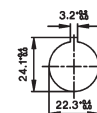

0,8 Nm

Dimensions:

LSM16 Z16..., LSM25 Z16..., ..A2

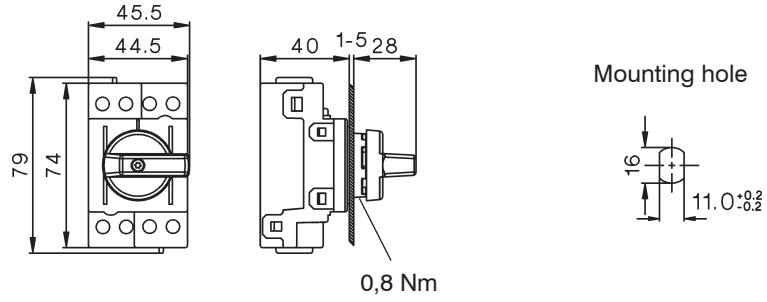

LSM16 Z16..., LSM25 Z16..., ..A2+2, ..A4

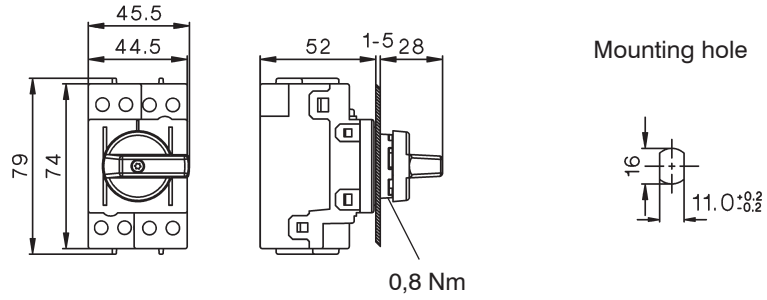

LSM16 VZV16..., LSM25 VZV..., ..A2

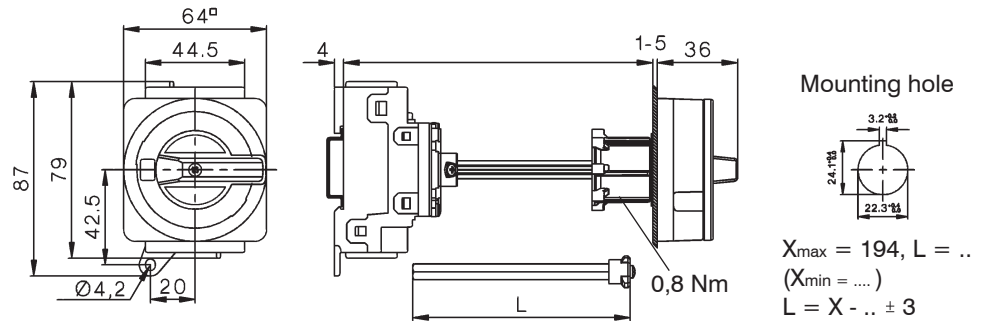

LSM16 VZV16..., LSM25 VZV..., ..A2+2, ..A4

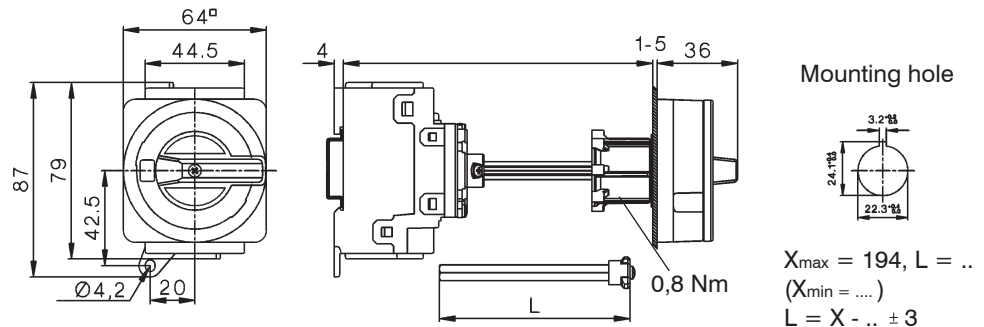

LSM16 SMA..., LSM25 SMA..., ..A2

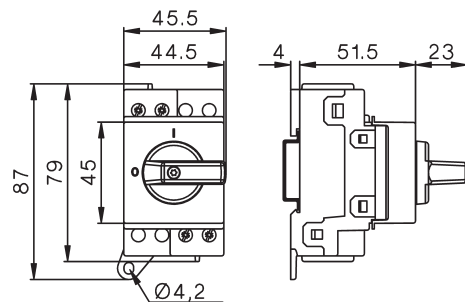

LSM16 SMA..., LSM25 SMA..., ..A2+2, ..A4

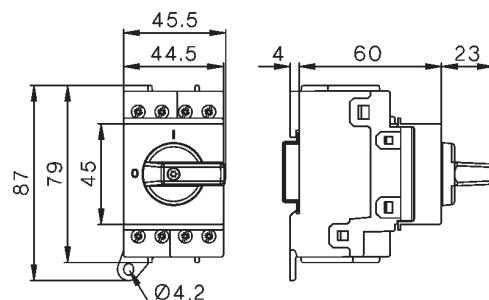

Dimensions:

**LSM16 SMAH1..., LSM25 SMAH1...,
..A2**

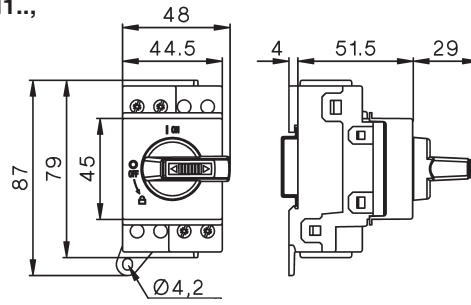

**LSM16 SMAH1..., LSM25 SMAH1...,
..A2+2, ..A4**

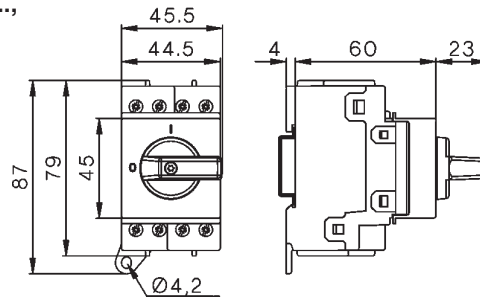

**LSM16 PFLH4..., LSM25 PFLH4...,
..A2, ..A2+2, ..A4**

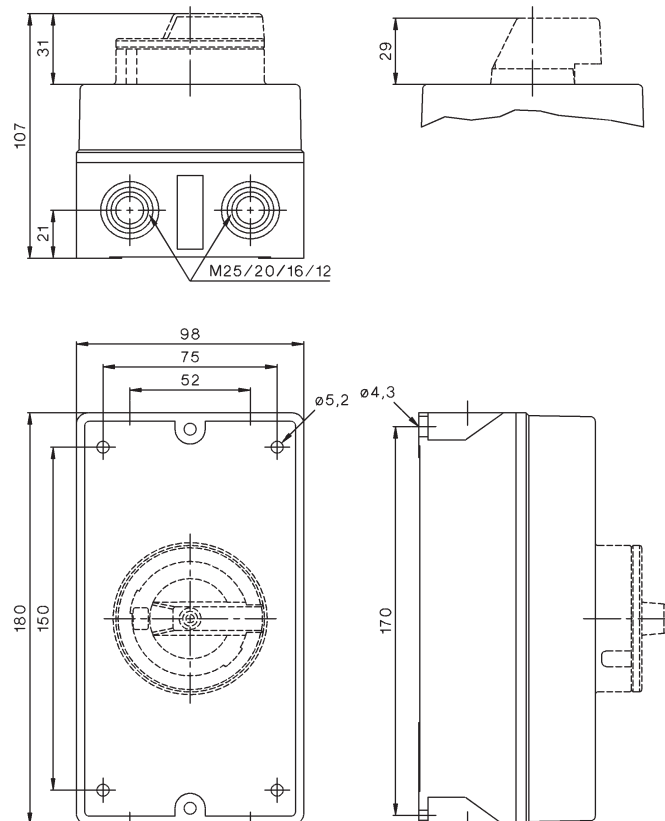



Quality



D912E176



Lieblgasse 7, A-1220 Wien
Telefon: +43 1 251 51- 0
Fax: +43 1 251 51-89
e-mail: sales@benedict.at
www.benedict.at

